

Manual Supplement

Manual Title:	5128A Operators	Supplement Issue:	3
Print Date:	December 2016	Issue Date:	1/18
Revision/Date:		Page Count:	4

This supplement contains information necessary to ensure the accuracy of the above manual.



Change #1, 415, 498, 499, 500, 537

On page 6, under **Humidity and Temperature Chamber Technical Specifications**, add the following to the end of the paragraph:

unless otherwise noted.

Replace the **Chamber Uniformity and Stability** table with:

Chamber Uniformity and Stability

Ambient Temperature Range: 23 °C ±3 °C ^[1]						
Chamber Temperature	Chamber Humidity Range		Chamber Temperature Uniformity ^[2]	Chamber Humidity Uniformity ^[2]	Chamber Humidity Stability ^[3]	Chamber Temperature Stability ^[3]
	Min % RH	Max % RH				
18 °C to 28 °C	7 % RH	See Chamber Operational Range below	±0.12 °C	±0.3 % RH	±0.15 % RH	±0.05 °C
The following specifications are typical for chamber conditions shown ^[4]						
5 °C to <18 °C ^[5]	15 % RH	See Chamber Operational Range below	±0.5 °C	±1.5 % RH	±0.5 % RH	±0.5 °C
>28 °C to 30 °C	7 % RH		±0.2 °C	±0.6 % RH	±0.3 % RH	±0.2 °C
>30 °C to 35 °C	7 % RH		±0.3 °C	±0.9 % RH	±0.4 % RH	±0.3 °C
>35 °C to 40 °C	7 % RH		±0.5 °C	±1.5 % RH	±0.5 % RH	±0.5 °C
>40 °C to 50 °C	7 % RH		±0.5 °C	±1.5 % RH	±0.5 % RH	±0.5 °C
<p>[1] For ambient temperature range of 23°C ±5°C, multiply the specifications by 1.5.</p> <p>[2] Defined as the uniformity of the Working Volume.</p> <p>[3] Defined as 1-sigma standard deviation of measurement readings over a 5-minute span.</p> <p>[4] Chamber humidity uniformity is listed for mid-level humidity settings. Lower humidity settings will give better uniformity while higher humidity settings will give worse uniformity.</p> <p>[5] The chamber control range is 5 °C to 50 °C. Achievable low temperature may be limited to 15 °C below ambient dependent upon stabilization time and temperature and humidity settings.</p>						

On page 8, Table 2, replace the Silicone row with:

Silicone Unit Under Test (UUT) grommets, 0.25 in, 0.375 in, 0.5 in, 0.75 in, 0.875 in	One of each size, 5 in total
---	------------------------------

On page 13, replace Table 5, with:

Table 5. Working Chamber

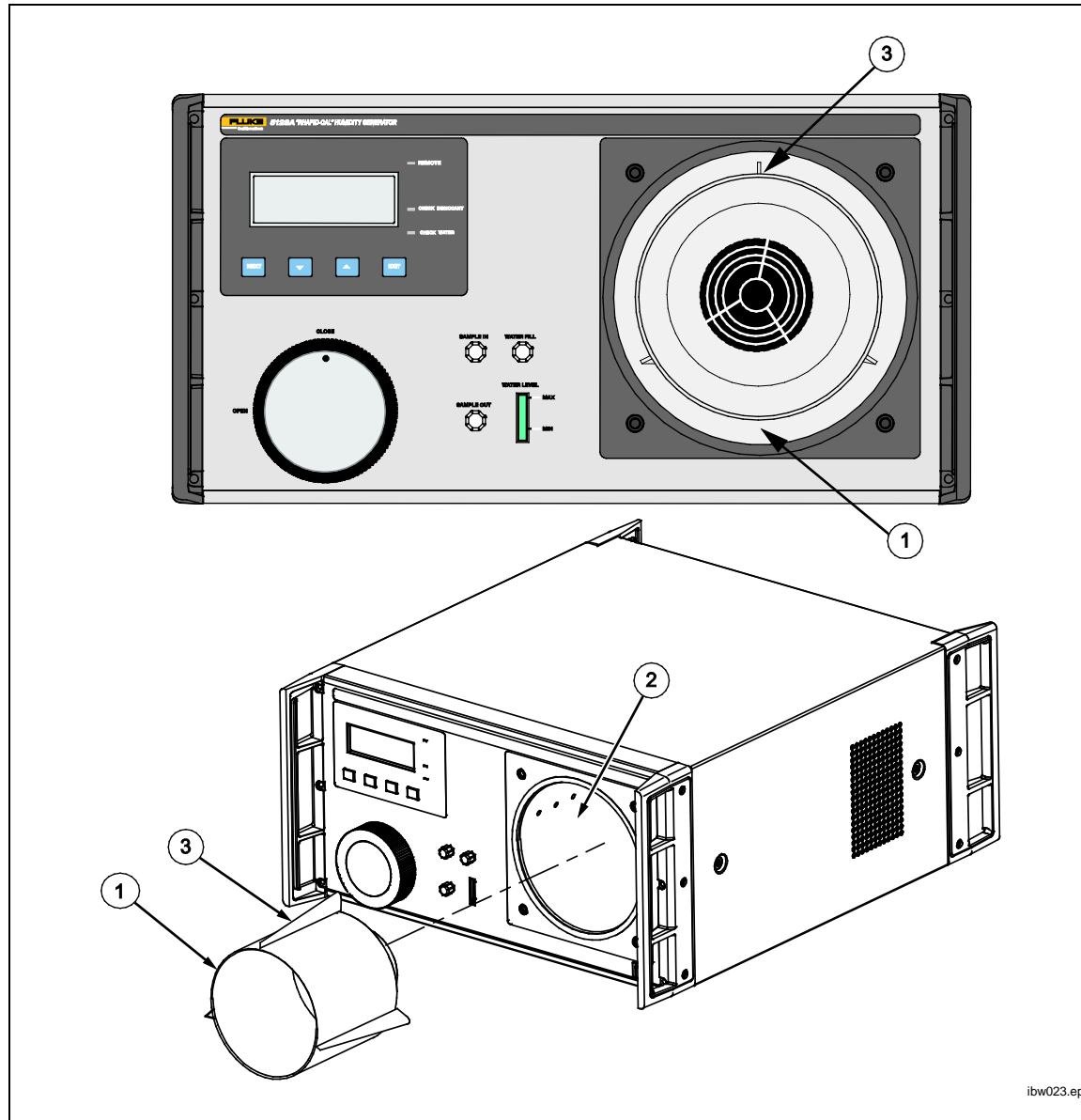

Item	Name	Description
①	Mixing Insert	Causes the air to circulate in a certain manner that gives better temperature and humidity uniformity inside the insert. The volume inside the insert is the <i>working area</i> where the Product guarantees its performance per the Product specifications. See the end of this manual for a template that outlines the working area. One of the three tabs on the outer part of the insert must be in the 12 o'clock position as shown in the illustration (③). This position ensures the best temperature and humidity uniformity within the working area.
②	Outer Chamber	The chamber where the mixing insert is placed. The UUT can be placed directly into the outer chamber without the mixing Insert, but the temperature and humidity will need to be monitored with an external reference probe.

On page 20 replace the *Mixing Insert* section with:

Mixing Insert

The mixing insert improves the temperature and humidity uniformity of the Product. It contains the working area that has guaranteed performance. The mixing insert can be removed to calibrate larger UUTs. In this case, use an external reference probe to monitor actual temperature and humidity conditions. Slide the mixing insert out of the chamber to remove it. To reinstall, align the posts on the mixing insert against the chamber walls and gently slide it back into the rear of the chamber. One of the three tabs on the outer part of the insert must be in the 12 o'clock position as shown in Table 5. This position ensures the best temperature and humidity uniformity within the working area.

To check for water condensation, remove the mixing insert from the chamber and then reinstall it.

On page 36, replace Table 11 with:

Table 11. Calibration Steps

Step	Temperature Set Point	Humidity Set Point	Dew Point Reading	Temperature Reading	Calculated RH	Low T Tolerance	High T Tolerance	Low RH Tolerance	High RH Tolerance
1	18 °C	7 %				17.86 °C	18.14 °C	6.3 %	7.7 %
2	18 °C	30 %				17.86 °C	18.14 °C	29.3 %	30.7 %
3	23 °C	20 %				22.86 °C	23.14 °C	19.3 %	20.7 %
4	28 °C	20 %				27.86 °C	28.14 °C	19.3 %	20.7 %
5	18 °C	45 %				17.86 °C	18.14 °C	44.3 %	45.7 %
6	23 °C	45 %				22.86 °C	23.14 °C	44.3 %	45.7 %
7	28 °C	45 %				27.86 °C	28.14 °C	44.3 %	45.7 %
8	18 °C	80 %				17.86 °C	18.14 °C	79.3 %	80.7 %
9	23 °C	80 %				22.86 °C	23.14 °C	79.3 %	80.7 %
10	23 °C	95 %				22.86 °C	23.14 °C	94.13 %	95.88 %
11	28 °C	70 %				22.86 °C	23.14 °C	69.3 %	70.7 %

Change #2, 524

Replace page 9 with:

Fill the Product with Distilled Water

Connect the Product to mains power (*see Mains Voltage*) and turn the switch on. Fill the Product with 50 ml to 60 ml of clean, distilled water (see Figure 1).

Note

It is difficult to see the water level if the Product is not On.

1. Remove the fill cap from the front panel (see *Front Panel*).
2. Use the fill syringe and insert the extension tube over the fill inlet on the Product.
3. Carefully pour water into the syringe. Bring the syringe to a higher level than the fill inlet and allow water to flow into the Product. Watch the water level indicator to gauge the fill level as the reservoir is filled. The Product takes approximately two syringes of water.
4. Monitor the water level indicator to ensure the water level is between the Max and Min lines.

⚠ Caution

To avoid damage to the Product, do not overfill the Product. If the Product is overfilled, water may flood the chamber. Use the drain port on the back of the Product to drain excess water. If water is found within the chamber, it must be wiped dry with a clean paper towel.

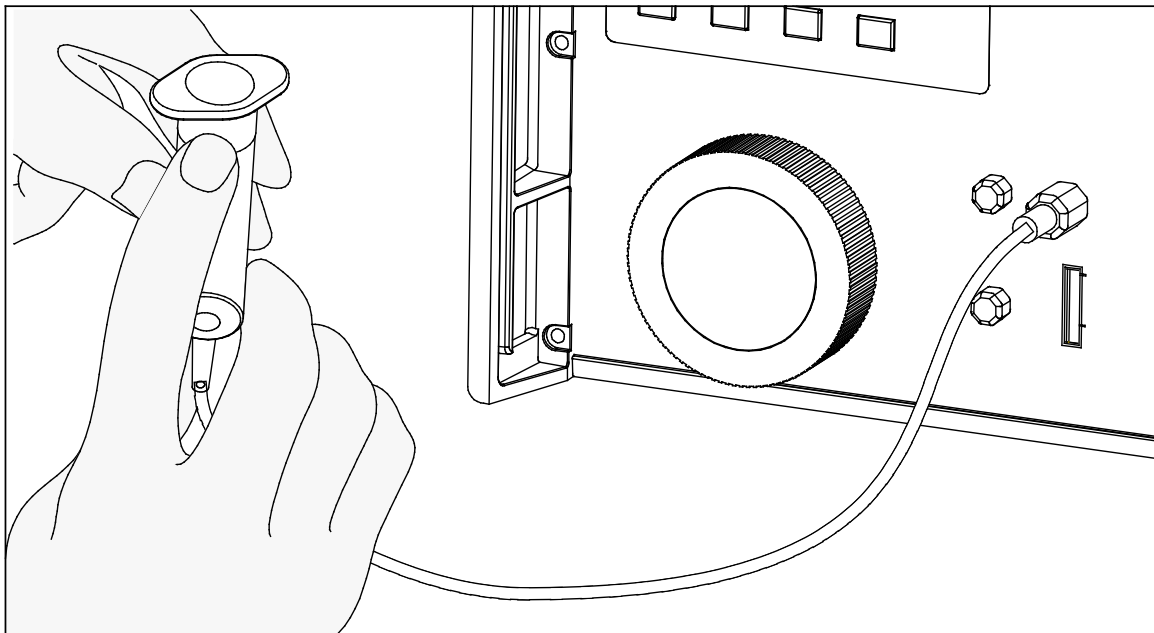

ibw009.eps

Figure 1. Fill the Water Level