



DIFFERENTIAL MODE INTERCONNECTIONS KIT, P/N 401581, INCLUDES

- | | | | | | |
|-----|----------|-----------------------------------|-----|--------|------------------------------|
| • 1 | 401583 | Differential Mode Controller | • 2 | 101977 | Quick Connect, 4T |
| • 2 | 100319 | Adapter, 1/8 in. NPT M x 2T | • 2 | 102116 | Quick Connect, 1/8 in. NPT F |
| • 1 | 101529 | Tee, 4T | • 1 | 101348 | Cap, 2T |
| • 1 | 101450-Z | Tubing, PFA, 0.25 in. OD x 200 cm | • 1 | 101326 | Cap, 4T |
| • 2 | 101988-Z | Tubing, SS, 0.125 in. OD x 100 cm | • 1 | 560036 | Instruction Sheet |

(OPTIONAL) DIFFERENTIAL MODE REFERENCE VOLUME, P/N 401582 INCLUDES:

- | | | | | | |
|-----|--------|---------------------------|-----|----------|-----------------------------------|
| • 1 | 401591 | Static P Reference Volume | • 1 | 101450-Z | Tubing, PFA, 0.25 in. OD x 100 cm |
| • 1 | 400528 | DH200 M x 4T adaptor | | | |

INSTALLATION INSTRUCTIONS

❶ Install the RPM3 (if present) into the Differential Mode Controller

- *If a DHI RPM3 is being used as the source of static pressure measurement, it can be installed directly into the Differential Mode Controller. If a different static measurement pressure device is being used, it may be connected to the connection tube described in ❶g. or to any other convenient connection on the TEST LOW side of the system.*

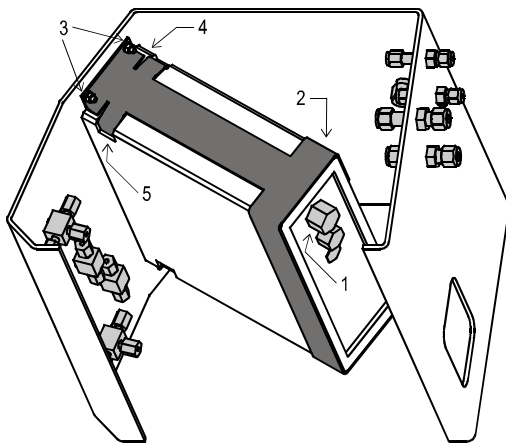

- a. Install a 1/8 in. NPT M x 2T adaptor in the RPM3 test port (1).
- b. Remove the RPM3 rack mount bracket(2) from the Differential Mode Controller (DMC) by removing the four M4 hex nuts and lock washers (3) on the inside of the DMC front panel.
- c. Remove the four screw caps(4) from the top of the RPM3 and remove the feet (5) from the bottom.
- d. Pull the sides of the rack mount bracket apart and slide the RPM3 into the bracket until the back is flush with the back of the bracket(6).
- e. Press the sides of the bracket back in, pushing the four tabs near the front of the bracket into the RPM3 screw slots (4 and 5).
- f. Secure the RPM3 in the rack mount bracket to the DMC using the four M4 hex nuts and lock washers (3) that were removed in Step ❶b.
- g. Locate the RPM TEST port connection tube inside the DMC bracket. It is the 1/8 in. PFA tube with swage nut and ferrules installed that is secured by a wire tie. Cut the wire tie and connect the tube to the adapter on the RPM3 test port (1).

❷ Locate the Differential Mode Controller (DMC)

Place the DMC at a convenient location relative to the PG7000 and the pressure control component (PPC or MPC) with which it will be used. Consider easy access to the valves on the front panel and the device under test connections on the top surface. Allow access to make the pressure connections on the rear panel. Minimize the length of interconnecting tubing to the other system components where possible.

❸ Make DMC to PG7000 Connection

- a. Remove gland, collar and plastic plug from the PG7601 test port.
- b. Install gland and collar onto 1/8 in. tube x DH200 male adaptor.
- c. Install the adaptor (as assembled) into the PG7601 test port. Torque to 15 Nm (Newton meter).
- d. Cut 1/8 in. SS tubing (100 cm) to desired length and bend as needed to make the connection between the PG7000 TEST port and the DMC PG port. Note that 1/8 in. SS tubing can be bent by hand to desired shape but use caution not to kink the tube.
- e. Insert the tube fully into the swage nut on the port and tighten the swage nut until snug. This swages the ferrules onto the tube. Repeat at both ends.

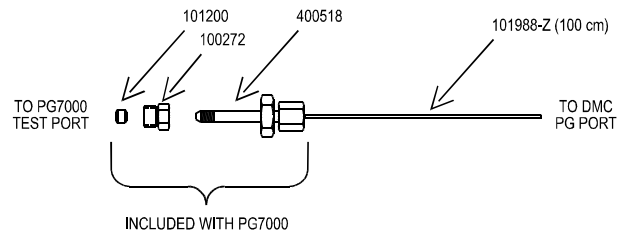

4 Make the DMC to pressure control component (PPC or RPM) connection

- Install a 1/8 in. tube x 1/8 in. NPT M adaptor into the TEST port of the PPC or MPC.
- Cut 1/8 in. SS tubing (100 cm) to desired length and bend as needed to make the connection between the PPC or MPC TEST port and the DMC PG/STATIC P CONTROL port. Note that 1/8 in. SS tubing can be bent by hand to desired shape but use caution not to kink the tube.
- Insert the tube fully into the swage nut on the port and tighten the swage nut until snug. This swages the ferrules onto the tube. Repeat at both ends.

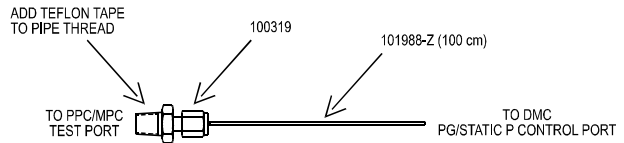
5 Make the connection to the Static P Reference Volume (if present)

- The Static P Reference Volume is optional. If the Static P Reference Volume is not present, the Differential Mode Controller STATIC P port may be left open to atmospheric pressure, capped using 4T cap P/N 101326, or connected to a different reference volume, as desired.

- Cut PFA tubing (100 cm) supplied with Static P reference volume to desired length to connect the DMC STATIC P port to the Static P Reference Volume.
- Insert the tube fully into the swage nut on the port and tighten the swage nut until snug. This swages the ferrules onto the tube. Repeat at both ends.

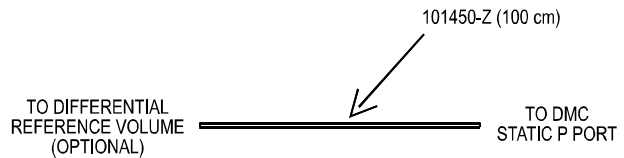
6 Make the direct connection to the pressure control component vacuum source (if desired)

- The DMC has a provision to allow the control vacuum or pressure source to be connected directly to the Static P Reference Volume. This can be useful to accelerate the setting of static pressure when the Static P Reference Volume is being used. The PG7000 Differential Mode Kit provides the hardware to connect the STATIC P CONTROL port to the standard VAC-MPC/PPC-REF vacuum pump for this purpose.

- Cut PFA tubing (200 cm) to desired length to connect the DMC STATIC P SUPPLY port to the VAC-PPC/MPC-REF vacuum pump.
- Install the 4T Tee on the vacuum pump between the “vacuum pump to PPC/RPM REFERENCE port” tube and the vacuum pump isolation valve.
- Insert the PFA tube fully into the swage nut on the free Tee port and tighten the swage nut until snug. This swages the ferrules onto the tube. Repeat at the other end on the Differential Mode Controller STATIC P SUPPLY port.

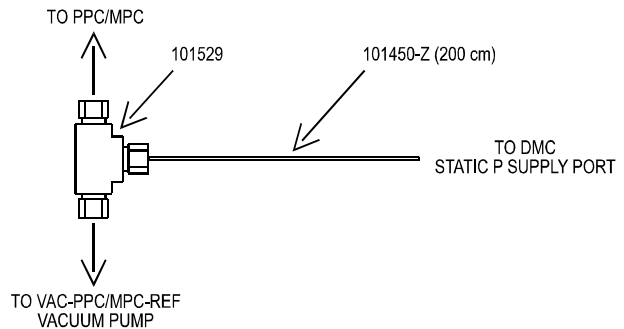
DMC SPECIFICATIONS

Maximum working pressure:

Test High side: 7 MPa (1 000 psi)

Test Low side: 300 kPa absolute (50 psia)

STATIC P REFERENCE VOLUME SPECIFICATIONS

Volume: 9.7 l (592 in.³)

Maximum Pressure: 20 MPa (3 000 psi)

PG7000. PPC and MPC are trademarks of DH Instruments, Inc.