

# 5522A Carry Case

## Instruction Sheet

### Introduction

The 5522A Carry Case (Carry Case) is a heavy duty protective case for the 5522A Multi-Product Calibrator (Calibrator). This Carry Case allows the Calibrator to be moved to areas in a manner that is compatible with sensitive electronic instrumentation. The Carry Case will not protect the Calibrator from shipment damage caused by the abuse and physical shock that can occur in general freight shipment services (see Caution below). To install the Calibrator in the Carry Case, follow the directions in this Instruction Sheet.

#### **⚠ Caution**

- **DO NOT ship or mail the Calibrator in the Carry Case. The Carry Case will not protect the Calibrator from shipment damage. An accessory Shipping Case (Model 55XX/ CASE) is available for purchase to ship the Calibrator.**
- **To prevent damage to the Calibrator, make sure the space around the product meets the minimum space requirements listed in the 5522A Multi-Product Calibrator Operators Manual.**

### How to Contact Fluke Calibration

To contact Fluke Calibration, call one of the following telephone numbers:

- Technical Support USA: 1-877-355-3225
- Calibration/Repair USA: 1-877-355-3225
- Canada: 1-800-36-FLUKE (1-800-363-5853)
- Europe: +31-40-2675-200
- Japan: +81-3-6714-3114
- Singapore: +65-6799-5566
- China: +86-400-810-3435
- Brazil: +55-11-3759-7600
- Anywhere in the world: +1-425-446-6110

To see product information and download the latest manual supplements, visit Fluke Calibration's website at [www.flukecal.com](http://www.flukecal.com).

To register your product, visit <http://flukecal.com/register-product>.

### Installation Kit

The parts necessary to complete this installation can be found in the Carry Case. To access the included parts, open the Carry Case as shown in Figure 1.

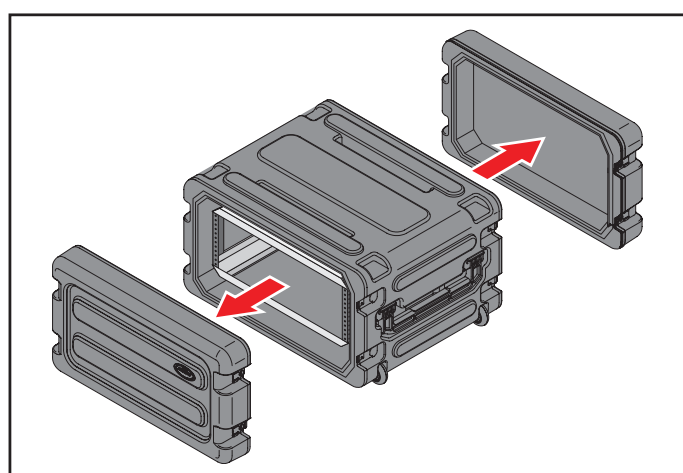

gqr01.eps

Figure 1. How to Open the Carry Case

Table 1. Included Parts

Item	Part Name and Description	Qty
①	5/64" Allen Hex-Key Wrench	1
②	#8-32 x 1/2" Pan-head Phillips Screw	8
③	#10-32 x 3/4" Decorative-head Phillips Screw	4
④	#10-32 x 3/8", Pan-head Phillips Screw	4
⑤	Washer, Flat	4
⑥	Rack Ear "L" Brackets	2
⑦	Rear Attachment Bracket	2

## Installation Procedure

### Remove the Anti-skid Feet

1. Find a clean flat surface and set the Calibrator on its top.
2. Remove the four Anti-skid feet on the bottom of the Calibrator as shown in Figure 2.

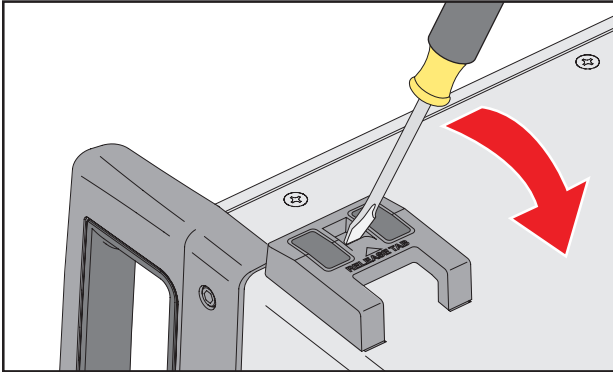

gqr04.eps

Figure 2. How to Remove the Anti-skid Feet

### Install the Rack Ears

1. Use the Allen Hex Key Wrench supplied in this kit to remove the top and bottom attachment screws on the front left and right handles as shown in Figure 3.
2. Install the Rack Ears on the front left and right handles with two #8-32 x 1/2" Pan-head Phillips Screws as shown in Figure 3.

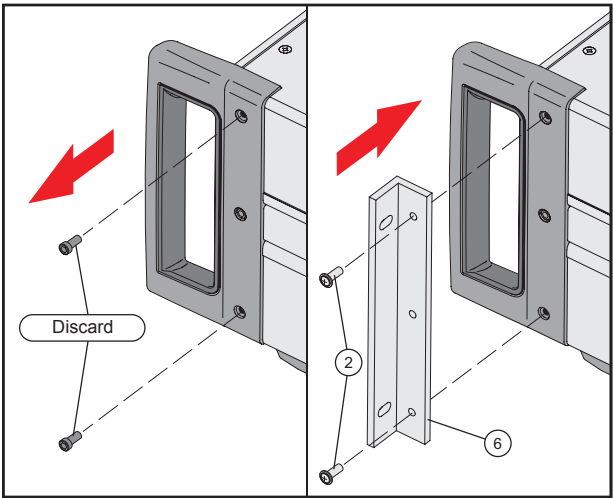

gqr02.eps

Figure 3. How to Install the Rack Ears

### Install the Rear Brackets

1. Use the Allen Hex Key Wrench supplied in this kit to remove the top and bottom attachment screws on the left and right rear handles as shown in Figure 4.
2. Install the Rear Attachment Brackets on the rear left and right handles with two #8-32 x 1/2" Pan-head Phillips Screws as shown in Figure 4.

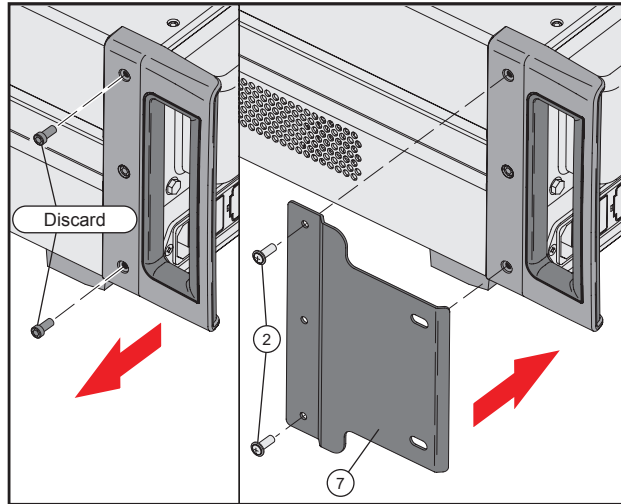

gqr03.eps

Figure 4. How to Install the Rear Brackets

### Install the Calibrator in the Carry Case

1. Set the Carry Case on the Rear Airflow Spacers (see Figure 5).

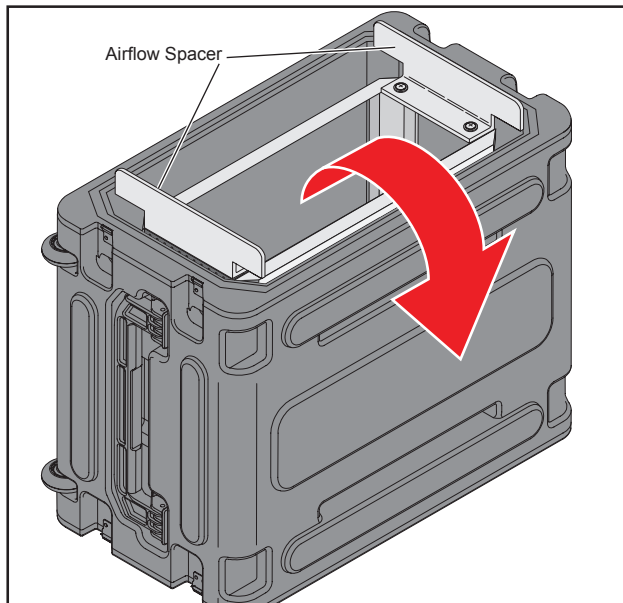

gqr07.eps

Figure 5. Location of Rear Airflow Spacers

- Carefully put the Calibrator in the Carry Case as shown in Figure 6. Attach the front Rack Ears of the Calibrator to the internal Carry Case frame with four #10-32 x  $\frac{3}{4}$ " Phillips Decorative-head Screws (two for each Rack Ear).

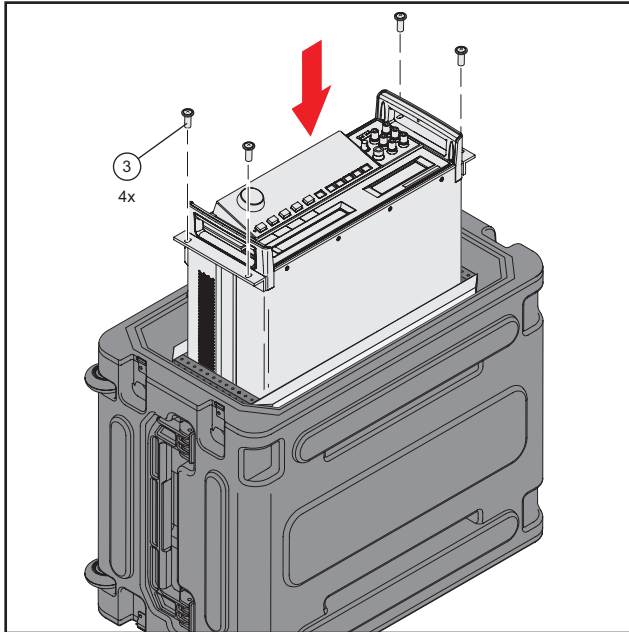

gqr05.eps

**Figure 6. How to Attach the Front of the Calibrator**

- After you have attached the front of the Calibrator to the Carry Case, carefully move the Carry Case to access to the rear of the Calibrator.
- Attach the rear of the Calibrator to the internal Carry Case frame with four #10-32 x  $\frac{3}{8}$ " Pan-head Phillips Screws and Washers (two for each Attachment Bracket) as shown in Figure 7.

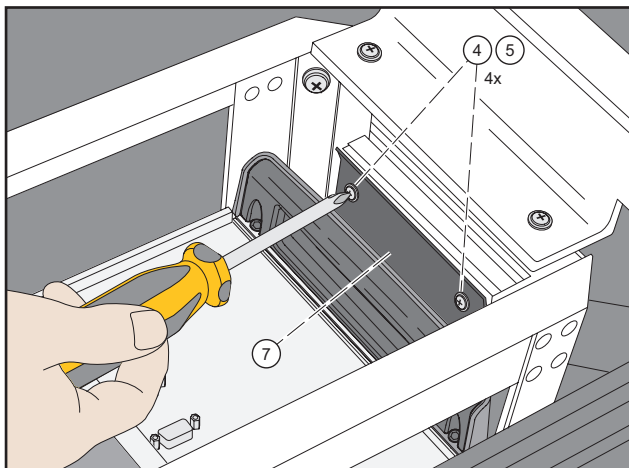

gqr06.eps

**Figure 7. How to Attach the Rear of the Calibrator**

